



# OZ Optics

www.ozoptics.com

219 Westbrook Rd, Ottawa, ON, Canada, K0A 1L0 Toll Free: 1-800-361-5415 Tel:(613) 831-0981 Fax:(613) 836-5089 E-mail: sales@ozoptics.com

## DIFFERENTIAL POLARIZATION DELAY LINES

### Features

- Varies the delay between two polarization states
- Low loss
- Sub-picosecond resolution
- Wide wavelength range
- $\pm 50$  psec delay range
- Electronically controlled

### Applications

- PMD compensation in high speed communications networks
- PMD emulation
- TDM bit alignment
- Interferometric sensors
- Coherent telecommunications



Differential Delay Line

### Product Description

OZ Optics' new differential delay line represents the next stage in controlling polarization mode dispersion in optical networks. The device splits the light within a fiber into orthogonal polarizations, and then actively varies the time that one polarization travels compared to the other polarization before combining the two polarizations together again. With this technique, one can introduce up to  $\pm 50$  picoseconds of optical delay in a system. The resolution of the device is better than 0.003 picoseconds, thus providing a high degree of control. The device is easily controlled by a computer via an RS-232 interface. Home and End position sensors allow easy monitoring of the device status and prevent any potential damage to the device.



JAPAN  
**DEVICE**

URL: <http://j-device.com>

営業: [sales@j-device.com](mailto:sales@j-device.com)

TEL: 03-6262-3424

日本デバイス株式会社

FAX: 03-6800-5883

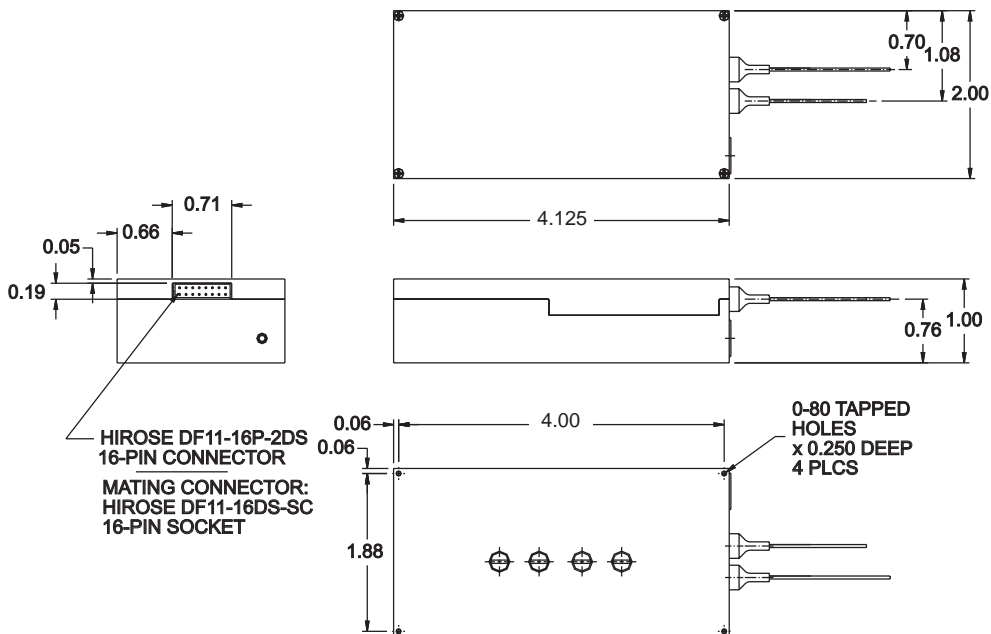

Figure 1: Differential Delay Line Dimensions (inches)

### Ordering Information for Standard Parts:

Bar Code	Part Number	Description
13600	DDL-650-11-1550-9/125-S-60-3A3A-1-1-MC/RS232	Electrically Controlled Differential Delay Line for 1550nm, with 60dB return loss. Pigtails are 1 meter long, 0.9mm OD tight buffered 9/125 SM fibers, with FC/APC connectors. Controlled via an RS232 protocol.

### Standard Product Specifications:

Delay Range (psec)	±50
Delay Resolution (psec) <sup>1</sup>	0.0027
Max. Insertion Loss (dB) <sup>2,3</sup>	<1.2
Polarization Dependent Loss (dB) <sup>3</sup>	<0.25
Zero Delay Accuracy (psec)	±0.1
Repeatability (psec)	<0.05
Size (LxWxH) (mm)	105x51x25 (4.12"x2"x1")
Return Loss (dB)	-40, -50, -60
Speed (psec/sec)	3
Supply Voltage	6-8 Volts
Supply Current	Max 180 mA
Interface	RS232 or TTL

<sup>1</sup> Theoretical, based on thread pitch and motor/encoder resolution.

<sup>2</sup> Includes variation of insertion loss over the entire travel range.

<sup>3</sup> For 1550nm wavelengths, at room temperature

### Ordering Examples for Standard Parts:

A customer needs to control polarization mode dispersion remotely in a network. The delays involved are 50 picoseconds or less. His system is sensitive to return losses, so a low return loss device is needed. He is currently using fibers with FC/APC connectors.

Bar Code	Part Number	Description
13600	DDL-650-11-1550-9/125-S-60-3A3A-1-1-MC/RS232	Electrically Controlled Differential Delay Line for 1550nm, with 60dB return loss. Pigtails are 1 meter long, 0.9mm OD tight buffered 9/125 SM fibers, with FC/APC connectors. Controlled via an RS232 protocol.

## Ordering Information For Custom Parts:

OZ Optics welcomes the opportunity to provide custom designed products to meet your application needs. As with most manufacturers, customized products do take additional effort so please expect some differences in the pricing compared to our standard parts list. In particular, we will need additional time to prepare a comprehensive quotation, and lead times will be longer than normal. In most cases non-recurring engineering (NRE) charges, lot charges, and a 1 piece minimum order will be necessary. These points will be carefully explained in your quotation, so your decision will be as well informed as possible. We strongly recommend buying our standard products.

## Questionnaire For Custom Parts:

1. What delay range (in psec or mm) do you need?
2. What resolution (in psec or mm) do you need?
3. Do you need a readout of the position?
4. What interface do you prefer for device control?
5. What wavelength will you be using?
6. What is the worst acceptable return loss?
7. What kind of fiber connectors are you using?
8. What size of cable should be used?
9. How long should the fibers be?

## DDL-650-11-W-a/b-S-LB-XY-JD-L -I

**W** = Wavelength: Specify in nanometers  
(Example: 1550 for 1550nm)

**a/b** = Fiber core/cladding sizes, in microns  
9/125 for 1300/1550nm Corning SMF-28  
singlemode fiber

**LB** = Backreflection level 40, 50 or 60dB  
(60dB is available for 1300 and 1550nm only)

**X,Y** = Connector code: Specify input connector  
followed by output connector

X = No connector  
3S = Super NTT-FC/PC  
3U = Ultra NTT-FC/PC  
3A = Angled NTT-FC/PC  
8 = AT&T-ST  
SC = SC  
SCA = Angled SC  
LC = LC  
LCA = Angled LC  
MU = MU

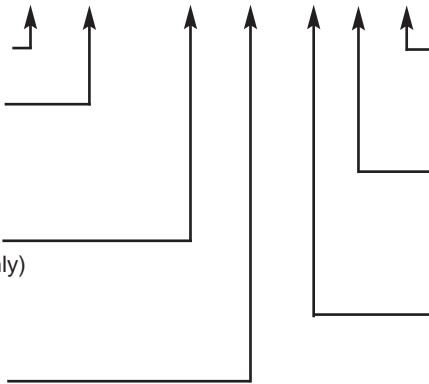

**I** = Interface

PC for base model with no microcontroller  
MC/RS232 for Intelligent RS232 Interface

**L**: Fiber length in meters, on each side of the device. If they are different, specify the input and output fiber lengths separated by a comma.  
Example: To order 1 meter of the fiber at the input and 7 meters at the output, replace the L with 1,7

**JD** = Fiber jacket type

1 = 900 micron OD hytel jacket  
3 = 3mm OD Kevlar reinforced PVC cable  
See the Standard Tables for other jacket sizes

## Ordering Examples for Custom Parts:

A customer is building a PDL emulation system to test PDL effects at 1480nm using RS232 control. He needs singlemode fiber pigtailed 1 meter long on each side, and does not need connectors. Because he is fusion splicing, he prefers uncabled fiber.

Part Number	Description
DDL-650-11-1480-9/125-S-60-XX-1-1-MC/RS232	Electrically Controlled Differential Delay Line for 1480nm, with 60dB return loss. Pigtailed are 1 meter long 0.9mm OD tight buffered 9/125 SM fibers, no connectors. Controlled via an RS232 protocol.

## Frequently Asked Questions (FAQs):

**Q:** Is the minimum delay zero picoseconds?

**A:** Yes. The delay can be positive or negative (ie, one polarization either lagging or leading the other polarization).

**Q:** Are the units calibrated?

**A:** Yes. The zero PMD reading is referenced to within  $\pm 1$ psec. All measurements are made relative to this value, with better than 0.002 psec resolution.

**Q:** What limits the accuracy of the 0 psec point?

**A:** Several issues. First, the zero point is determined with a PMD meter, which is limited in its accuracy. Second, the delay introduced by the device is also affected by how the fiber is coiled or bent during measurement and installation.

## Application Notes:

### Electrical Connections:

The differential delay line has a Hirose DF11-16P-2DS 16-pin connector to a wire harness terminated by a connector. This harness carries communication signals, power and ground lines. The pin designations are given below:

(1)	(3)	(5)	(7)	(9)	(11)	(13)	(15)
(2)	(4)	(6)	(8)	(10)	(12)	(14)	(16)

Hirose 16-pin connector

Pin	Name	Function	Comment
1	GND	Common Ground	
2	GND	Common Ground	
3	Select	Select TTL interface	For TTL interface, Input Active Low
4	Vin	Input DC supply voltage; (Min +6V Max +8V)	For ODL-300 Max 400mA For ODL-650 Max 180mA
5	Reverse	Move the motor in reverses	For TTL interface, Input Active Low
6	Rx	RS232- Receive input line	
7	Forward	Move the motor forward	For TTL interface, Input Active low
8	Tx	RS232- Transmit output line	
9	N/A	Do not connect	Factory use
10	N/A	Do not connect	Factory use
11	Reset	Hardware Reset line	Active Low, Min 100mS
12	N/A	Do not connect	Factory use
13	End	End limit switch	TTL output, active low
14	N/A	Do not connect	Factory use
15	Home	Home limit switch	TTL output, active low
16	N/A	Do not connect	Factory use

The differential delay line comes as a calibrated unit complete with fiber optic cable and specified connectors. The base of the DDL-650 has three 2-56 tapped mounting holes for attachment to a rack or printed circuit board. For best results, the mounting should be rigid and free of vibration. Do not over-tighten the mounting screws and use screws that thread in no more than 2mm. The Differential Delay Line is shipped with custom fiber optic cables attached. Both the cable and connectors (with strain-relief boots) are customer-specified. Clean the optical connectors and attach them in circuit with the input broadband signal.

**Example Application:** Polarization mode dispersion (PMD) is an important issue in the quest to build high speed (10Gbs, 40Gbs, and higher) communication networks. An input signal travelling along a single mode fiber normally has some distortion, due to polarization mode dispersion. The signal effectively has been split into two arbitrary, yet orthogonal polarizations, and one polarization is leading the other. A differential delay line is a crucial element to PMD compensation.

The figure below shows how to use a delay line to compensate for polarization mode dispersion. A polarization controller is installed just before the differential delay line to convert the arbitrary polarizations from the input fiber into polarizations corresponding to the orthogonal polarization controlled by the differential delay line. The faster polarization is slowed down by the delay line and the combined signals then enter the output fiber to go to the receiver. A control system monitors the quality of the signal at the receiver, and dynamically adjusts the polarization and the delay to get the two signals to match up again. Thus the PMD in the system can be corrected in real time.

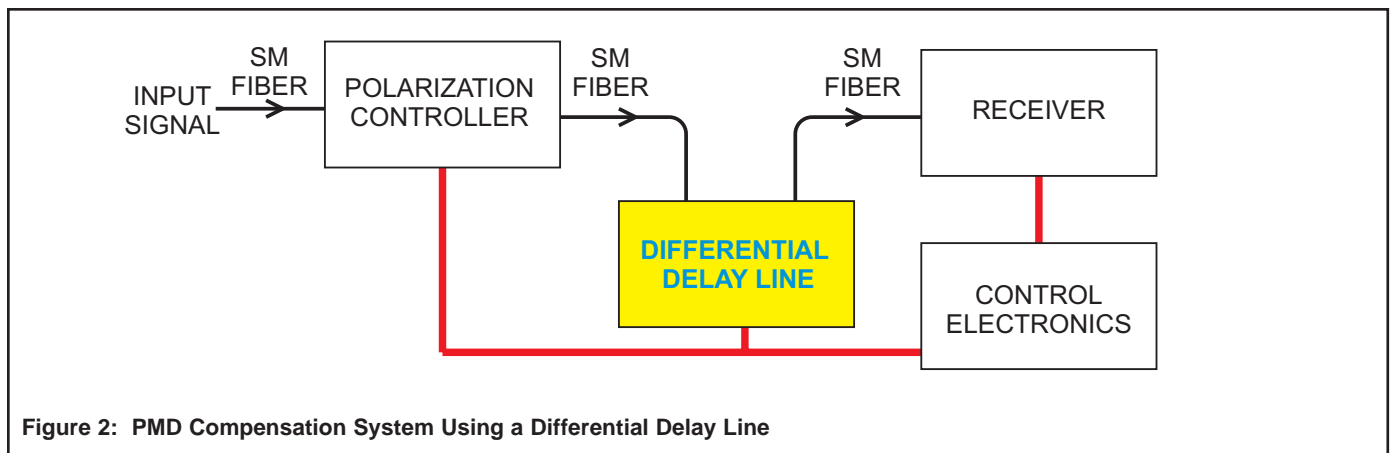

Figure 2: PMD Compensation System Using a Differential Delay Line