

## 1064 nm Polarization Insensitive Isolator (PSSI & PDSI Series)

Rev 11B

The 1064 nm Polarization Insensitive Isolator features a compact package, low insertion loss, high isolation, high return loss and excellent environmental stability and reliability. With unique design, the device can handle very high peak power. It is ideal for suppressing back reflection in fiber lasers and other high performance laser based fiber optics systems.

### Specifications

Parameter	Unit	Single Stage		Dual Stage	
		Grade P	Grade A	Grade P	Grade A
Center Wavelength ( $\lambda_c$ )	nm	1064			
Typ. Peak Isolation	dB	40	38	55	52
Min. Isolation, $\lambda_c$ , 23 °C, all polarization states	dB	30	28	45	42
Typ. Insertion Loss, $\lambda_c$ , 23 °C, all polarization states	dB	1.5	1.6	2.4	2.6
Max. Insertion Loss, $\lambda_c$ , -5 °C to +50 °C, all polarization states	dB	2.0	2.2	3.4	3.6
Min. Return Loss (Input/Output)	dB	55/50	55/50	55/50	55/50
Max. Polarization Dependent Loss, 23 °C	dB	0.15	0.15	0.15	0.15
Max. Average Optical Power	mW	300			
Max. Peak Power for ns Pulse	kW	10			
Max. Tensile Load	N	5			
Fiber Type		HI 1060 fiber			
Operating Temperature	°C	-5 to +50			
Storage Temperature	°C	-40 to +85			

\*IL is 0.5 dB higher, RL is 5 dB lower for each connector added.

### Package Dimensions

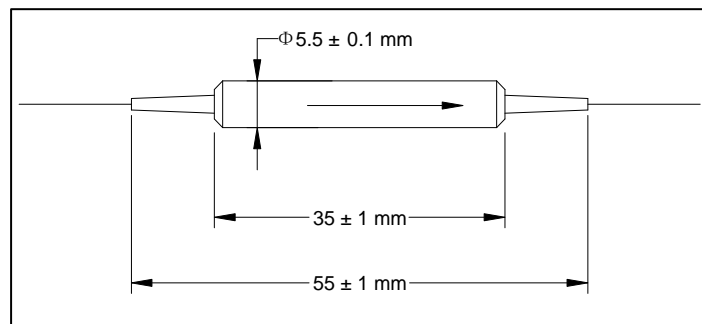

### Ordering Information

PSSI-06-①-②-③-④-⑤

PDSI-06-①-②-③-④-⑤

①: Grade

P - Premium

A - A grade

②: Connector Type

1 - FC/UPC

2 - FC/APC

3 - SC/UPC

4 - SC/APC

N - None

S - Specify

③: Fiber Jacket

B - 250  $\mu$ m bare fiber

L - 900  $\mu$ m loose tube

S - Specify

④: Fiber Length

1 - 1.0 m

S - Specify

⑤: Power Type

P - Pulse Application

C - Continuous Wave