

Preliminary



- Plug & play
- Single-pass & high-efficiency
- Compact & robust

Reference Specification sheet

Optics (General)	unit	Specification			Note
Mixer Type		Second Harmonic Generation (SHG)			
Mixer Pigtailling Type		1x1			
Input Wavelength	nm	1560			[1]
Output Wavelength	nm	780			
Input Fiber, Connector		PM1550, None			
Output Fiber, Connector		PM850, None			
Specified pump power	W	10			
Pump condition		CW, single longitudinal mode			
Optics (output)	unit	Minimum	Typical	Maximum	Note
Output power @ specified pump	W	1	1.1		
Residual IR/output power rejection ratio	dB	40			
Output polarization state		linear @ vertical axis			
Output PER	dB	18	20		
Back reflection of IR wavelength	dB		-45	-42	
Mechanics	unit	Specification			Note
Housing dimension (L*W*H)	mm	150x50x35			
Electrics	unit	Minimum	Typical	Maximum	Note
Electrical connector		Hiroschi HR 10G-10P(73)			
Thermoelectric cooler		3.2V, 4A maximum, Qc = 6.9 W			
NTC Thermistor resistance@25°C	kΩ	10			
Thermistor B vale (B25/85)	K	3478			
PD response	V/W		NA		[2]
Environment	unit	Minimum	Typical	Maximum	Note
Storage temperature (no humidity)	°C	-20	-	70	
Operating temperature range	°C	10	25	35	
Operating relative humidity (non condensing)	%RH	0	-	85	
Vibration / Shock		Refer to ISTA-2A			
Restriction of hazardous substances directive (RoHs)		Declaration of Conformity to 2011/65/EG			

[1] Different wavelength available upon request

[2] Photodiode power monitoring available upon request

- Mechanical drawing

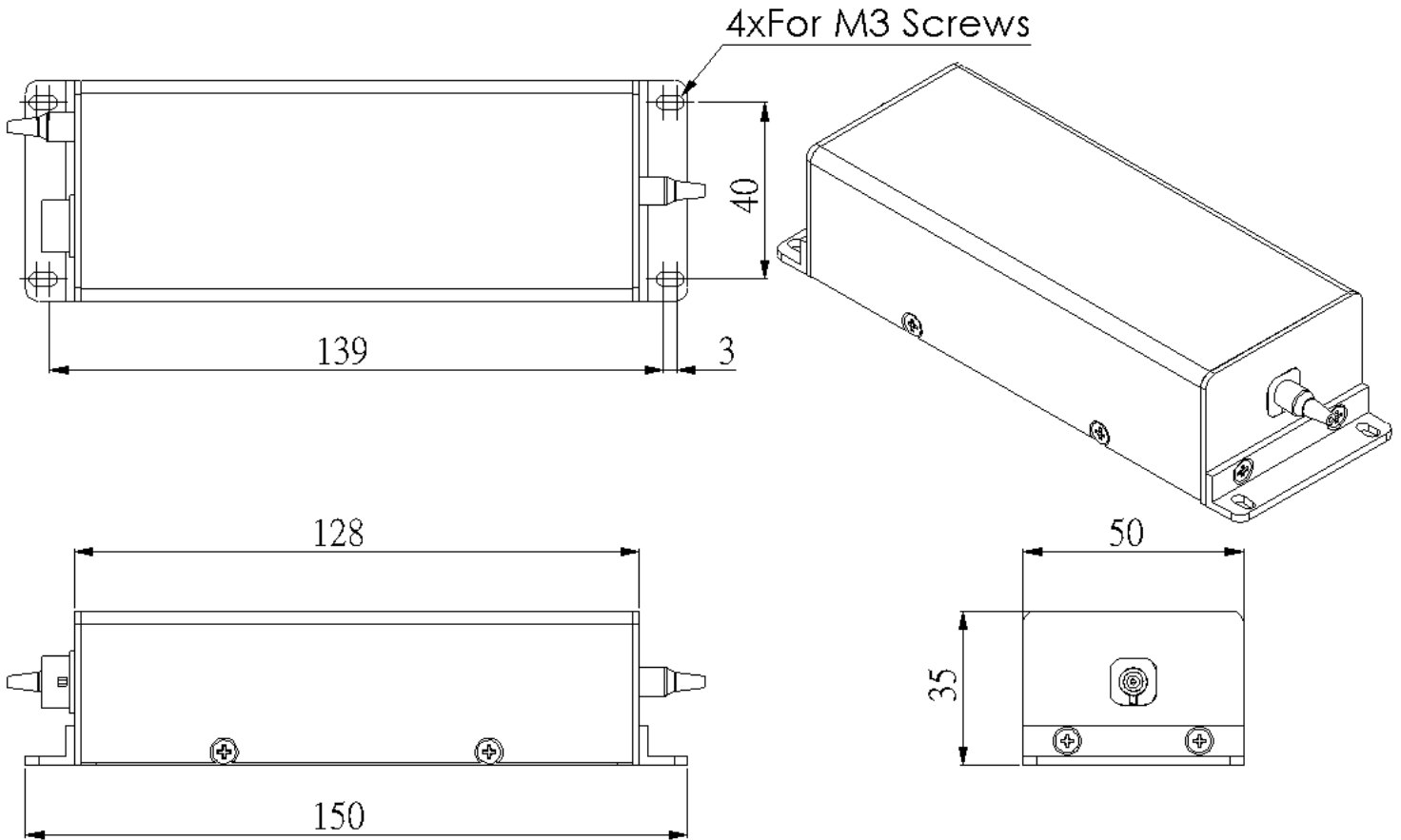

Unit: mm